

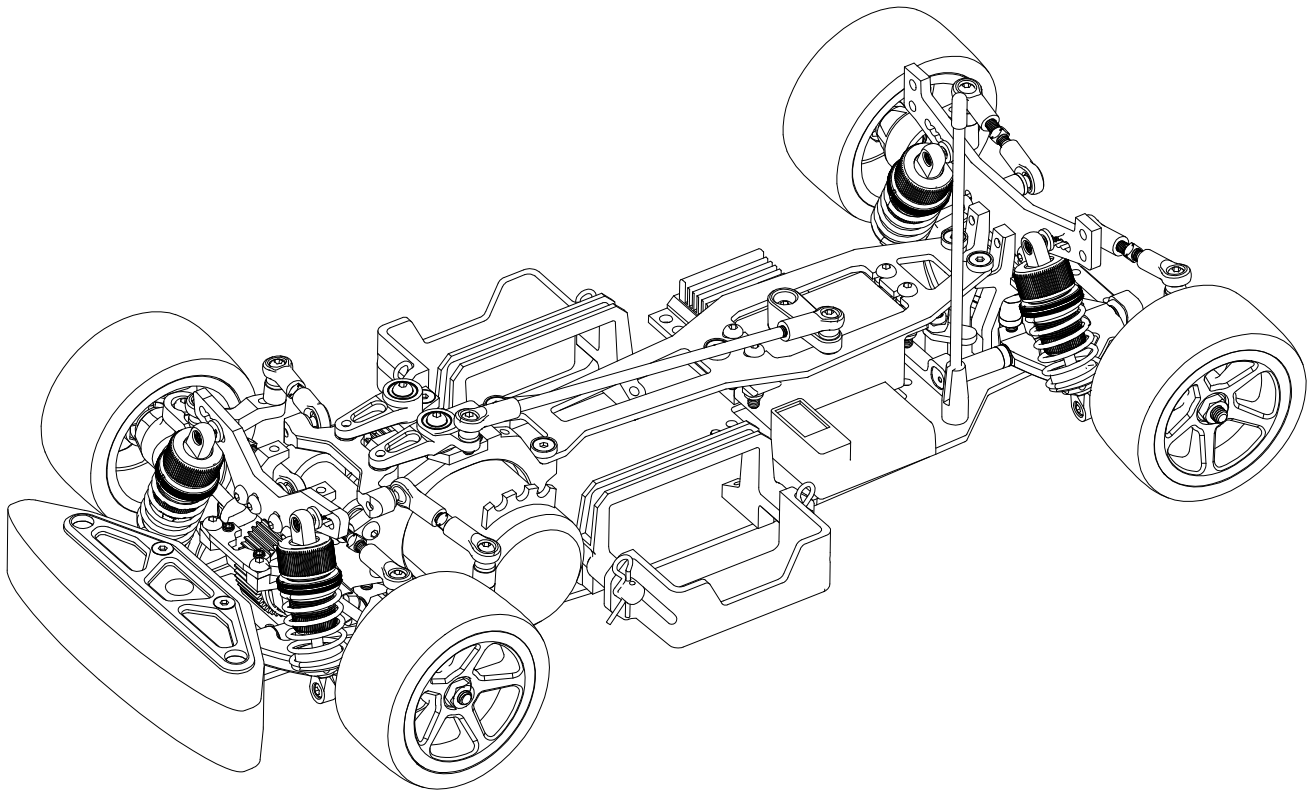

Yeah Racing Conversion Kit CK-M07

Wheel Base : 210 / 225 / 239 mm



CK-M07S (Require) :









- M07 Carbon Fiber Reinforced C Parts Uprights #54810
- M07 Carbon Fiber Reinforced D Parts Suspension Arms #54811
- M07 Spur Gear w/ Counter Gear #51601
- M07 33mm Double Cardan Joint Shaft #42312
- 50mm Damber Set(Yeah Racing DBB-2050 or Similar)
- Aluminum Hex Adaptor Set 12x5mm(Yeah Racing #WA-035 or Similar)
- M07 Ball Bearing(Yeah Racing #YB0301MX or Similar)
- Ball Bearing Steering Set(Tamiya #51599 or Yeah Racing #TAMC-035 or Similar)
- Pinions 06P 25T (Tamiya #50477 / Yeah Racing #MG-06P25T or Similar)
- Gear Differential (Yeah Racing #TAMC-040 or Similar)
- M07 Front Rear Stabilizer Set #54757 (Optional)

CK-M07R (Require) :

- M07 Carbon Fiber Reinforced C Parts Uprights #54810
- M07 Carbon Fiber Reinforced D Parts Suspension Arms #54811
- M07 Spur Gear w/ Counter Gear #51601
- M07 33mm Double Cardan Joint Shaft 2 pcs Black #42312
- 50mm Damber Set(Yeah Racing DBB-2050 or Similar)
- Pinions 06P 25T (Tamiya #50477 / Yeah Racing #MG-06P25T or Similar)
- M07 Front Rear Stabilizer Set #54757 (Optional)







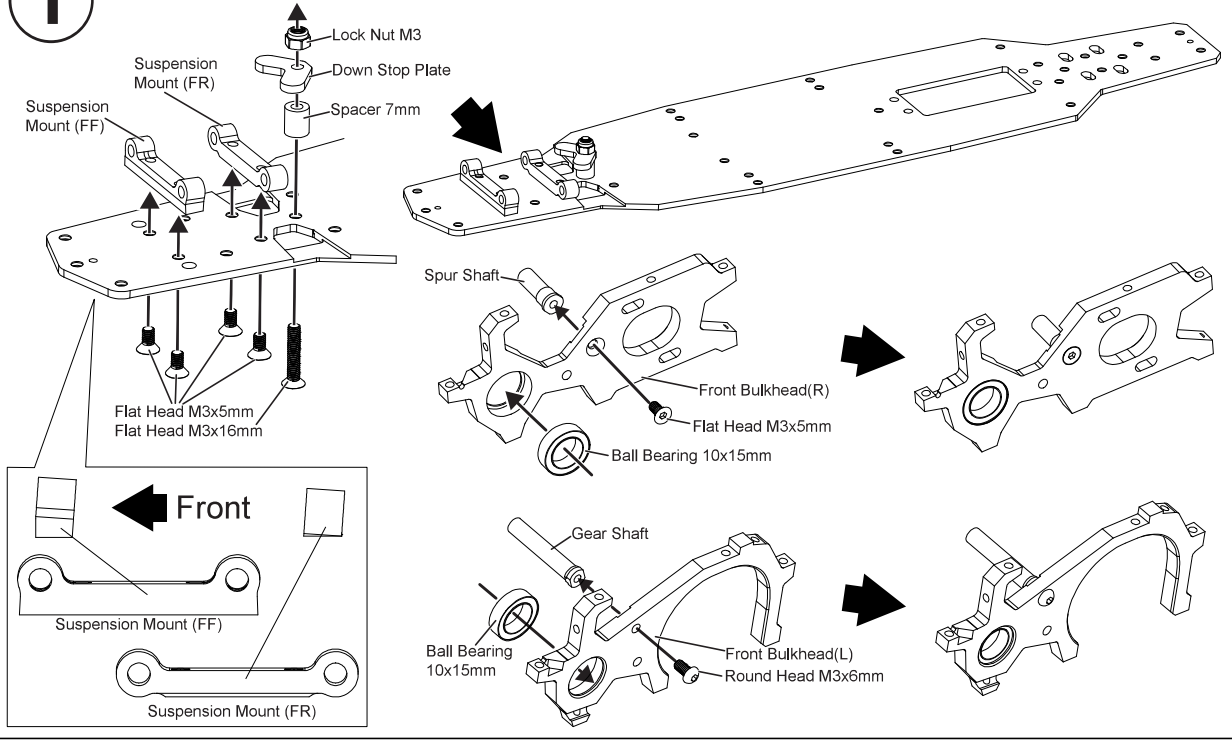



BAG A

1

-  Set Screw M3x3mm (2)
-  Set Screw M3x6mm (2)
-  Ball Ø4.8x5mm(2)
-  Round Head M3x6mm (1)
-  Round Head M3x8mm (2)
-  Flat Head M3x5mm (11)
-  Flat Head M3x6mm (3)
-  Flat Head M3x12mm (1)
-  Flat Head M3x16mm (1)







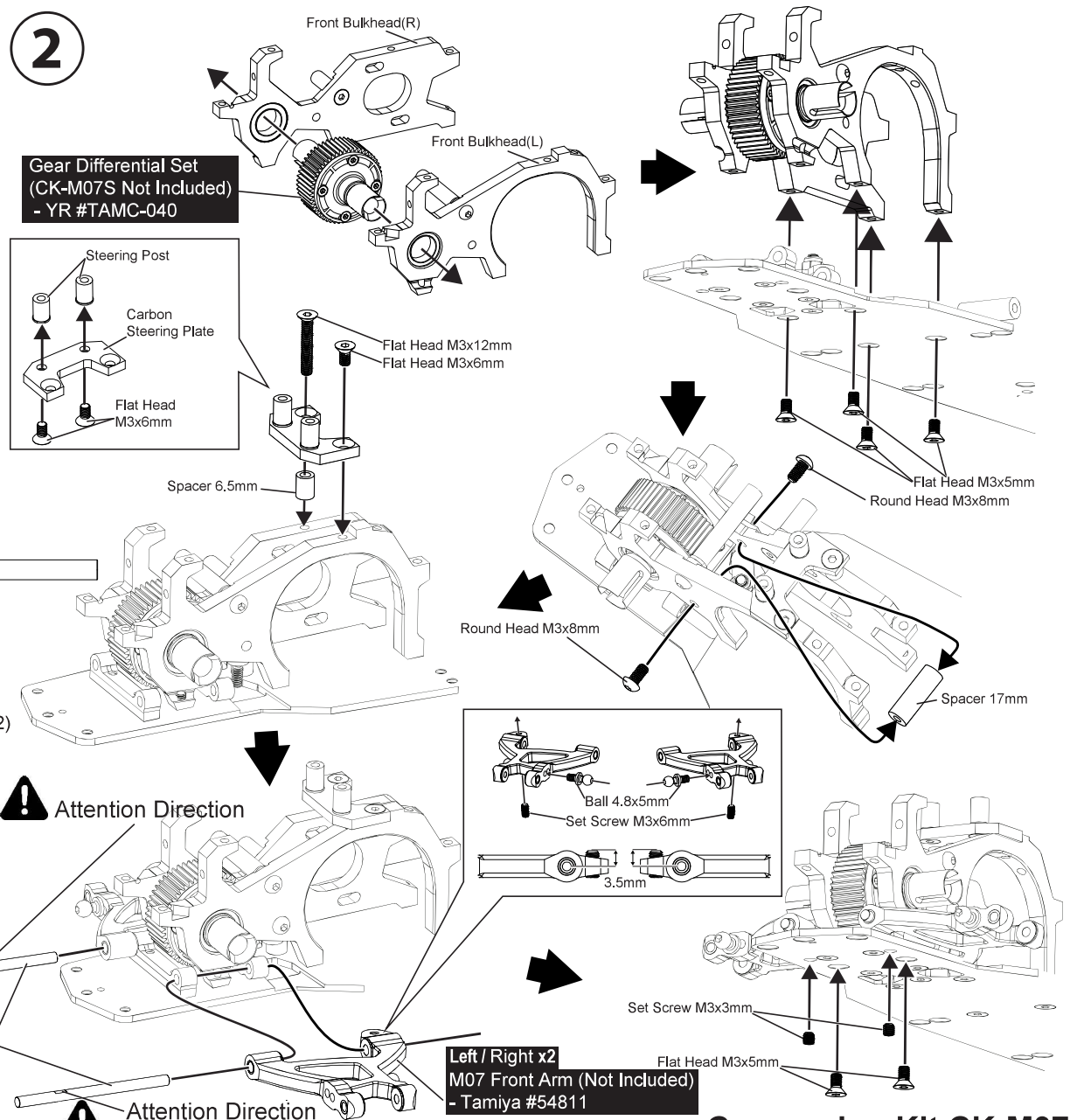

2

-  Lock Nut M3 (1)
-  Spacer 7mm (1)
-  Spacer 6.5mm (1)
-  Spacer 17mm (1)
-  Steering Post (2)
-  Down Stop Plate (1)
-  Spur Shaft (1)
-  Gear Shaft (1)
-  Front Arm shaft (2)
-  * Ball Bearing 10x15mm (2)
-  Carbon Steering Plate (1)



* CK-M07S Not Included

Left / Right x2
M07 Front Arm (Not Included)
- Tamiya #54811

-  Flat Head M3x5mm (7)
-  Flat Head M3x6mm (5)
-  Flat Head M3x16mm (1)
-  Round Head M3x6mm (4)
-  Round Head M3x12mm (2)
-  Round Head M3x16mm (4)

-  Lock Nut M3 (5)

-  Ball Ø4.8 (4)

-  Countersink Spacer (5)

-  Spacer 5mm (2)

-  Spacer 8mm (1)

-  Servo Mount Post (4)



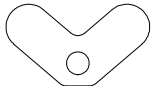



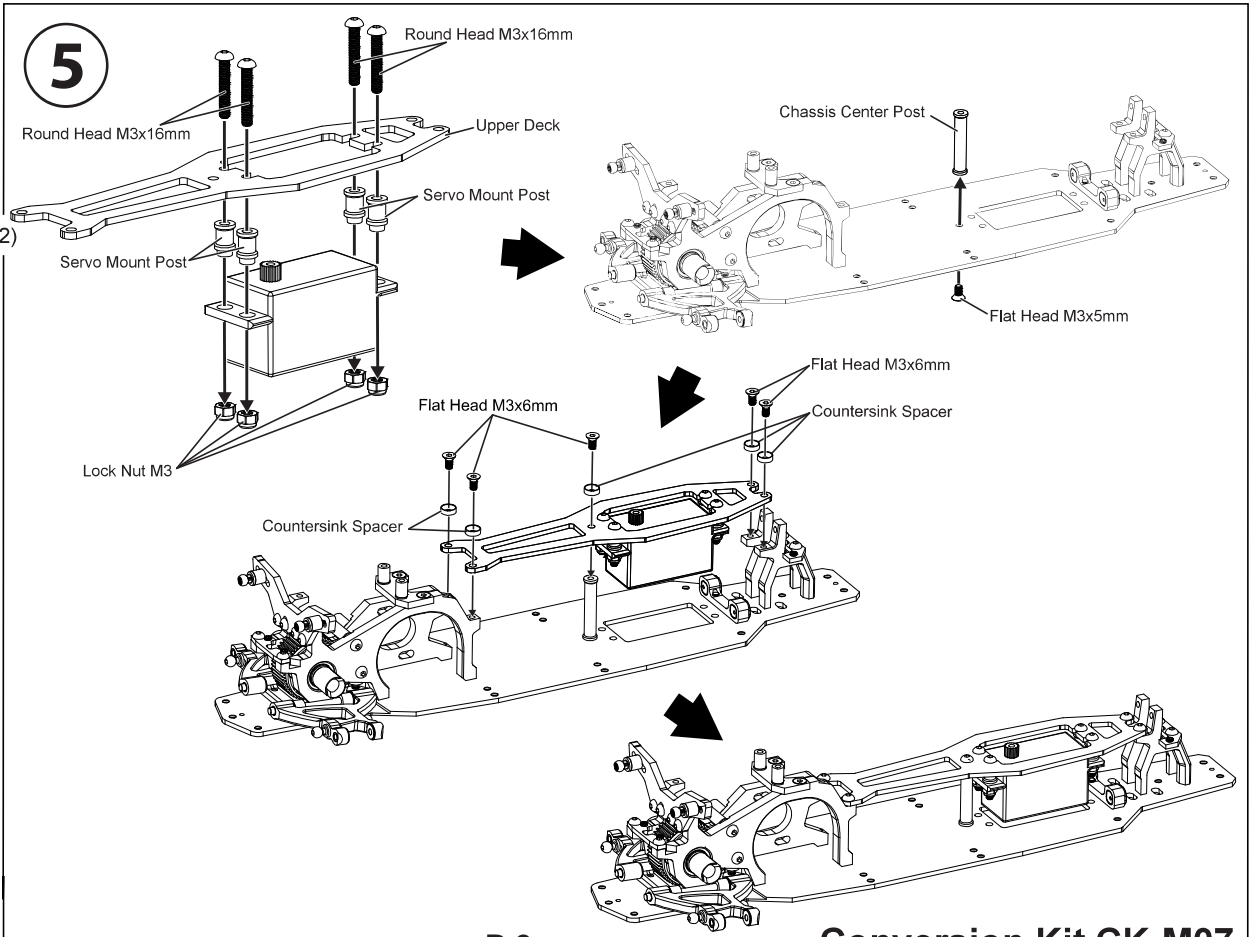
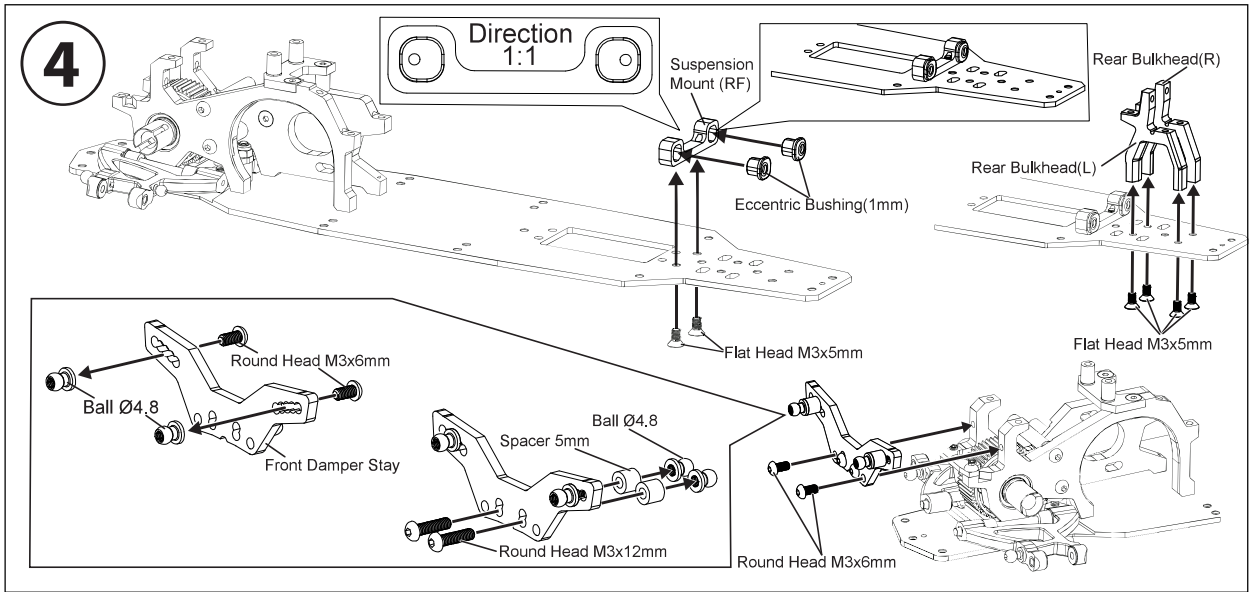
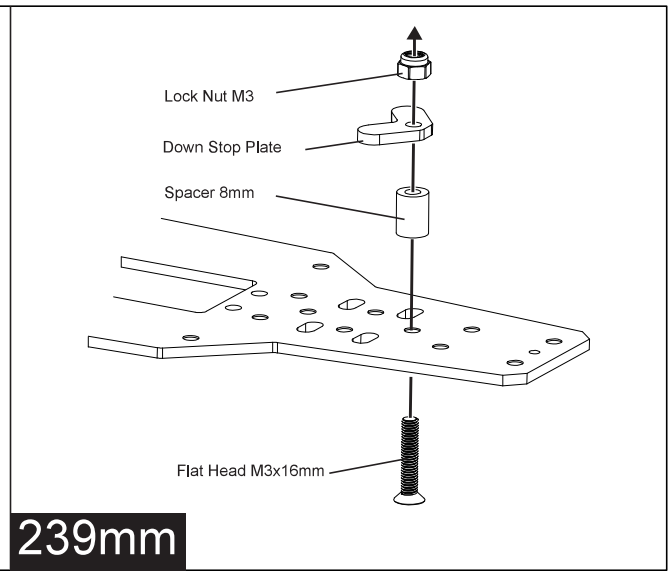
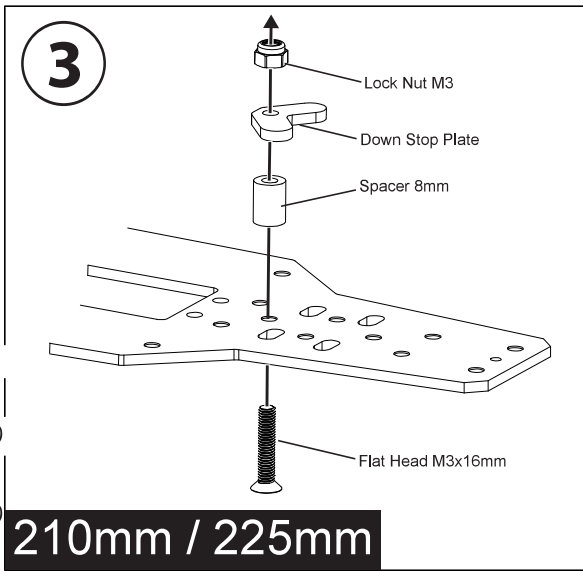







































-  Chassis Center Post (1)

-  Down Stop Plate (1)







-  Eccentric Bushing (1mm) (2)

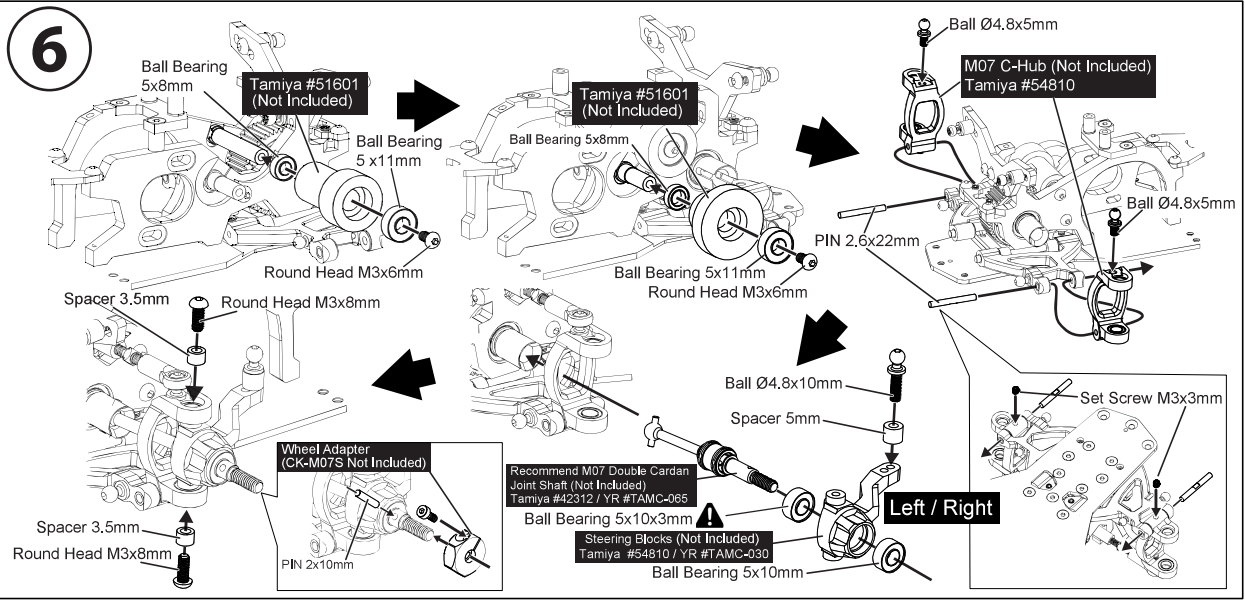





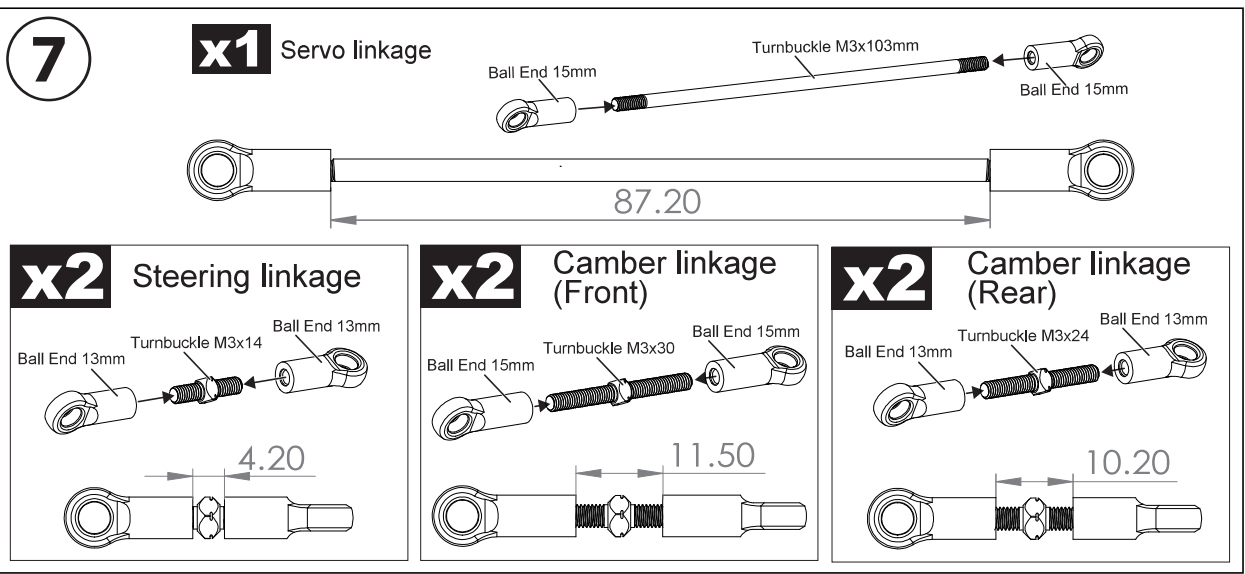

BAG B

-  Ball Bearing 5x8mm
-  Ball Bearing 5x11mm
-  Ball Bearing 5x8mm
-  Ball Bearing 5x11mm
-  Ball Bearing 5x10x3mm
-  Ball Bearing 5x10mm
-  Ball Bearing 5x11mm
-  Ball Bearing 5x10mm
-  Ball Bearing 5x10mm
-  Ball Bearing 5x10mm
-  Ball Bearing 5x10mm
-  Ball Bearing 5x10mm
-  Ball Bearing 5x10mm
-  Ball Bearing 5x10mm
-  Ball Bearing 5x10mm
-  Ball Bearing 5x10mm
-  Ball Bearing 5x10mm
-  Ball Bearing 5x10mm
-  Ball Bearing 5x10mm
-  Ball Bearing 5x10mm
-  Ball Bearing 5x10mm
-  Ball Bearing 5x10mm
-  Ball Bearing 5x10mm
-  Ball Bearing 5x10mm
-  Ball Bearing 5x10mm
-  Ball Bearing 5x10mm
-  Ball Bearing 5x10mm
-  Ball Bearing 5x10mm
-  Ball Bearing 5x10mm
-  Ball Bearing 5x10mm
-  Ball Bearing 5x10mm
-  Ball Bearing 5x10mm
-  Ball Bearing 5x10mm
-  Ball Bearing 5x10mm
-  Ball Bearing 5x10mm
-  Ball Bearing 5x10mm
-  Ball Bearing 5x10mm
-  Ball Bearing 5x10mm
-  Ball Bearing 5x10mm
-  Ball Bearing 5x10mm
-  Ball Bearing 5x10mm
-  Ball Bearing 5x10mm
-  Ball Bearing 5x10mm
-  Ball Bearing 5x10mm
-  Ball Bearing 5x10mm
-  Ball Bearing 5x10mm
-  Ball Bearing 5x10mm



-  Spacer 3.5mm(4)
-  Spacer 5mm(2)
-  * Ball Bearing 3x7mm(2)
-  * Ball Bearing 5x8mm(6)
-  * Ball Bearing 5x10mm(4)
-  * Ball Bearing 5x11mm(2)



-  Ball End 13mm(8)
-  Ball End 15mm(6)
-  Turnbuckle M3x14(2)
-  Turnbuckle M3x24(2)
-  Turnbuckle M3x30(2)
-  PIN 2.6x22mm(2)

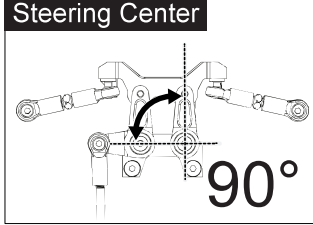
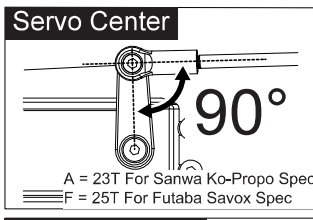
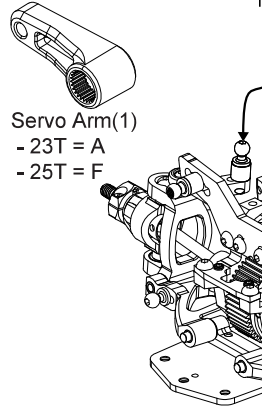
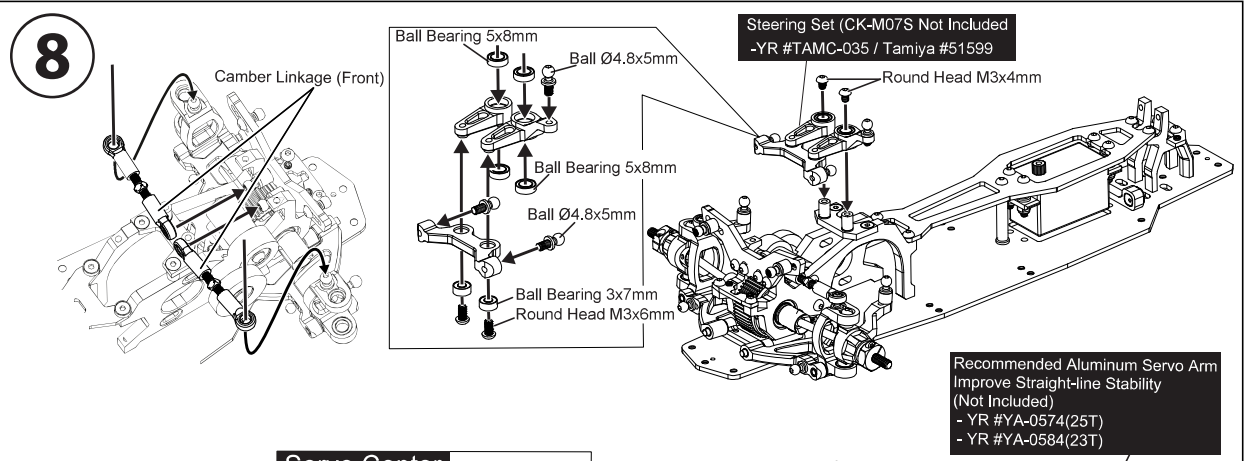

* CK-M07S Not Included

9

- Flat Head M3x5mm(10)
- Round Head M3x6mm(6)
- Set Screws M3x3mm(2)
- Set Screws M3x6mm(2)
- Ball Ø4.8x5mm(4)
- Ball Ø4.8x5mm(4)

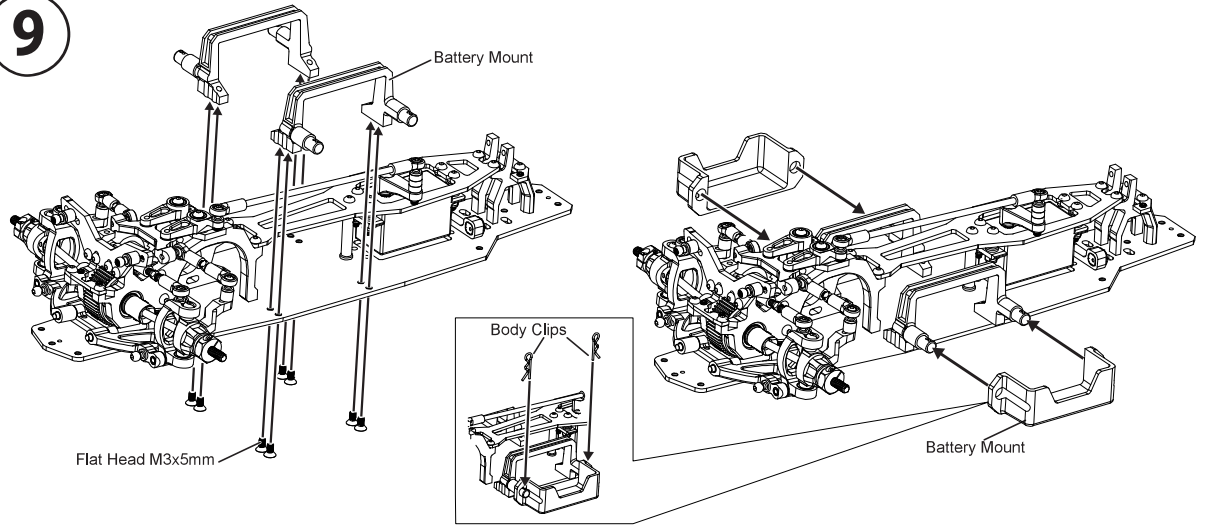

10

For : 210mm Wheel Base

- Spacer 2mm(2)
- Spacer 13.5mm(2)
- * Ball Bearing 5x10mm(4)
- Rear Wheel Axles(2)
- Eccentric Bushing (0mm)(2)
- Body Clips(4)
- PIN 2.6x25mm(2)
- PIN 3x57.5mm(2)
- Spacer 0.3mm(6)

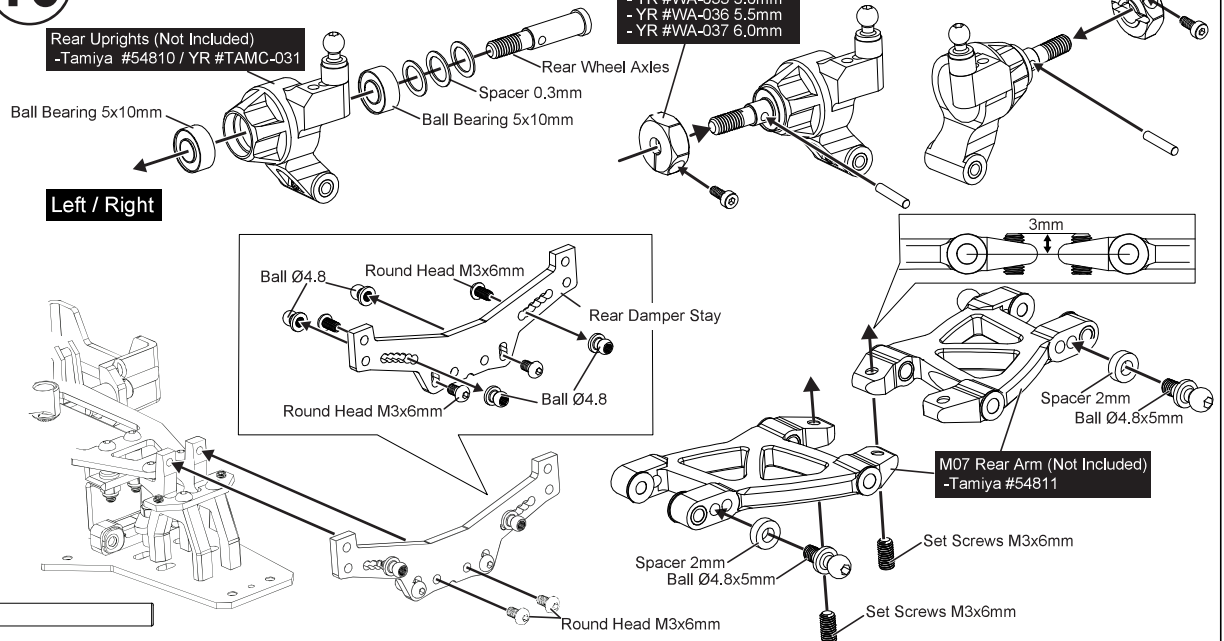





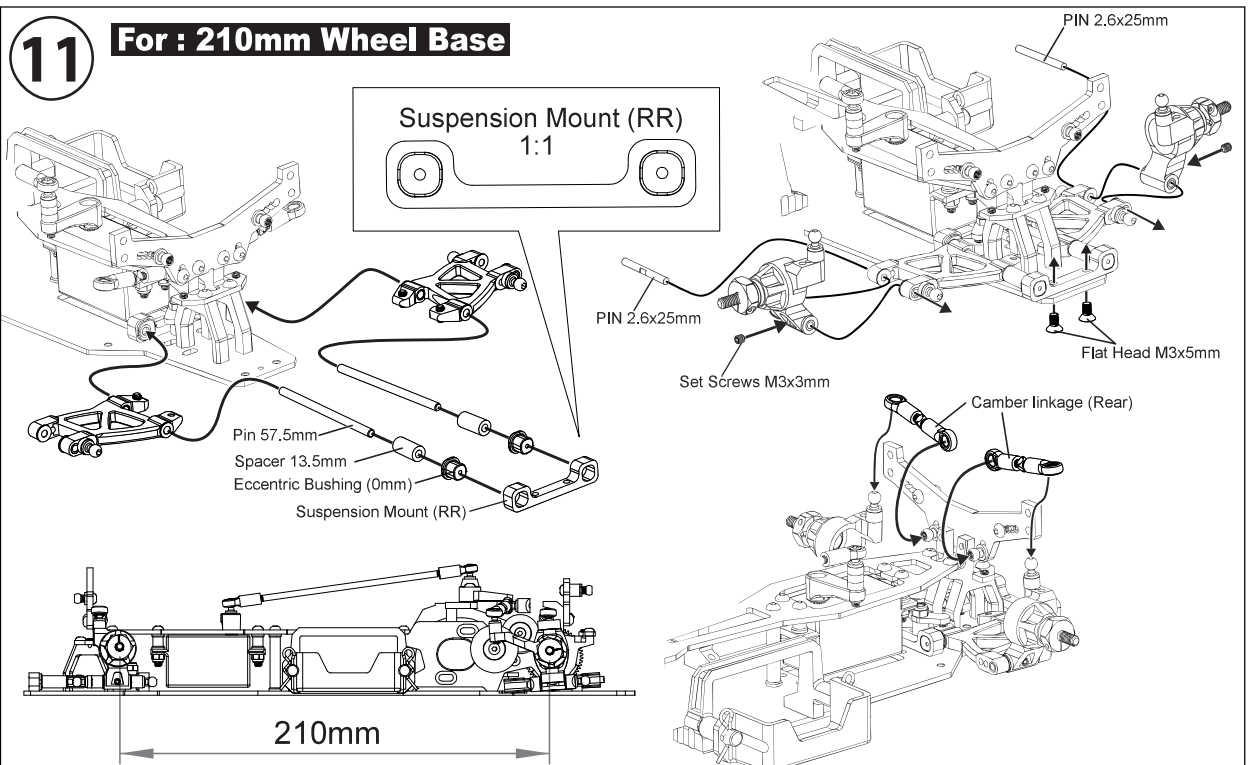



11



For : 210mm Wheel Base

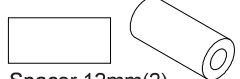

* CK-M07S Not Included

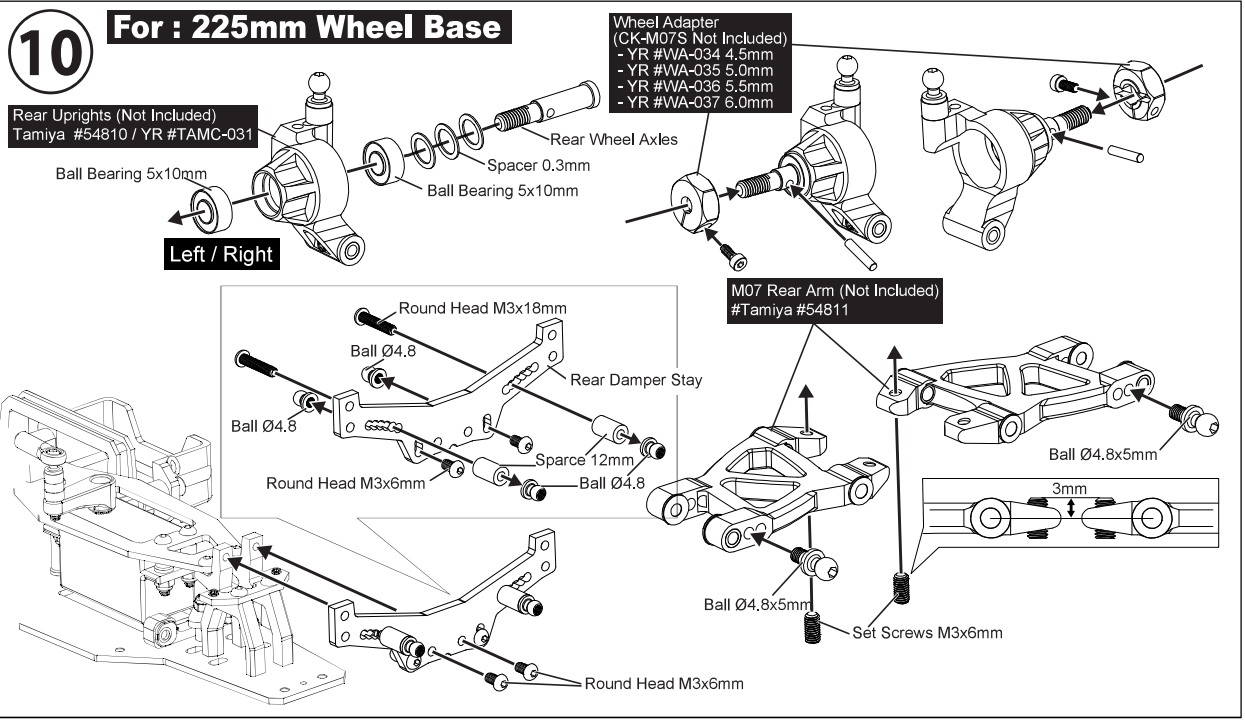
-  Flat Head M3x5mm (2)
-  Round Head M3x6mm(4)
-  Round Head M3x18mm(2)
-  Round Head M3x20mm(2)
-  Set Screws M3x3mm(2)
-  Set Screws M3x6mm(2)
-  Spacer 12mm(2)
-  Spacer 13.5mm(2)

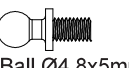

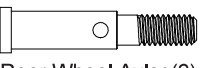
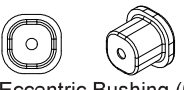
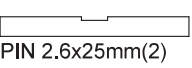
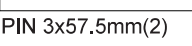
-  Ball Ø4.8(4)
-  Ball Ø4.8x5mm(4)
-  * Ball Bearing 5x10mm(4)
-  Rear Wheel Axles(2)
-  Eccentric Bushing (0mm)(2)
-  PIN 2.6x25mm(2)
-  PIN 3x57.5mm(2)

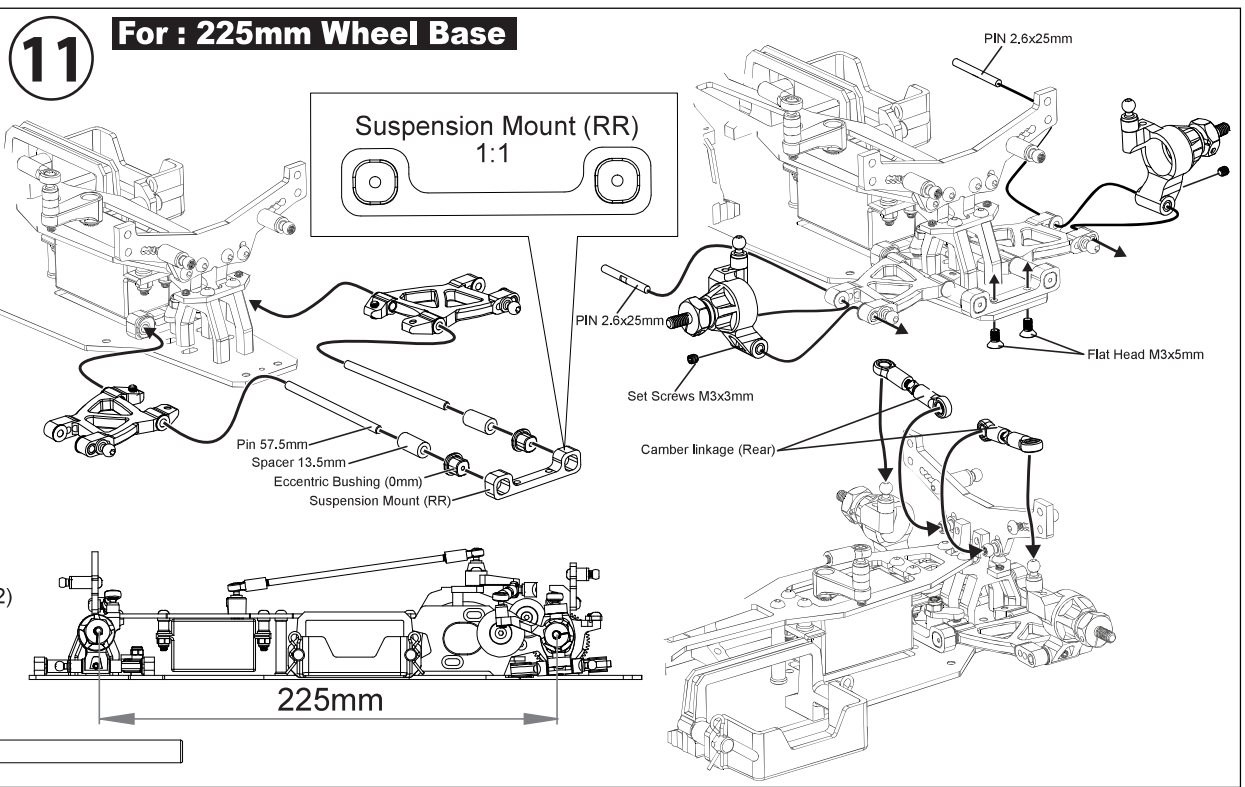

-  Spacer 0.3mm(6)
- * CK-M07S Not Included

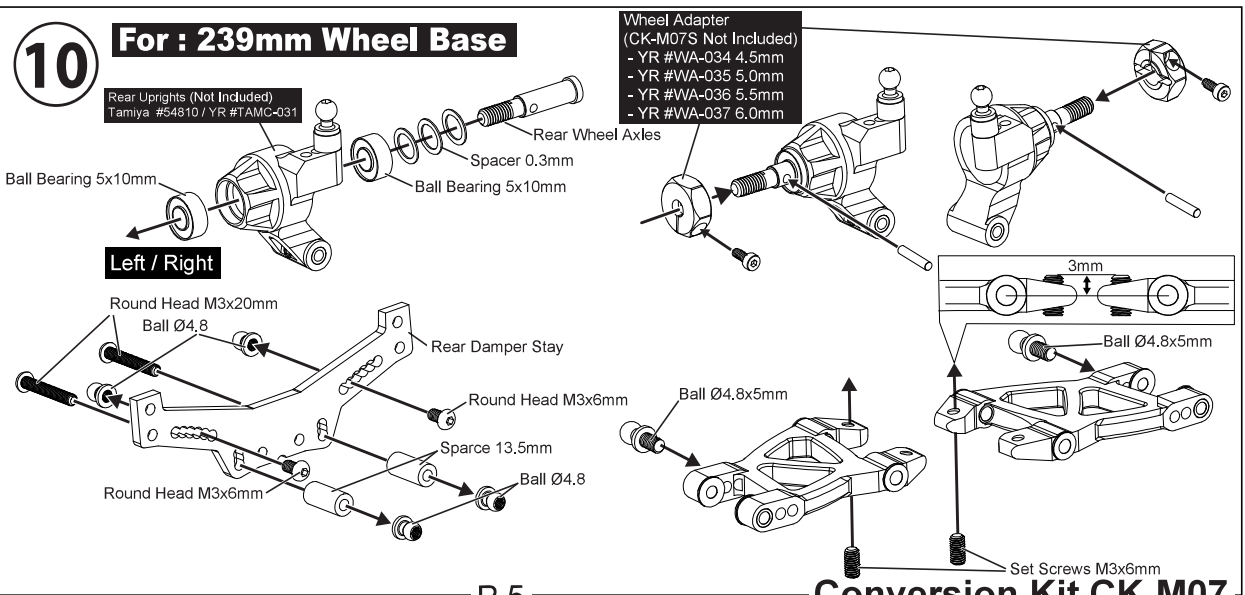

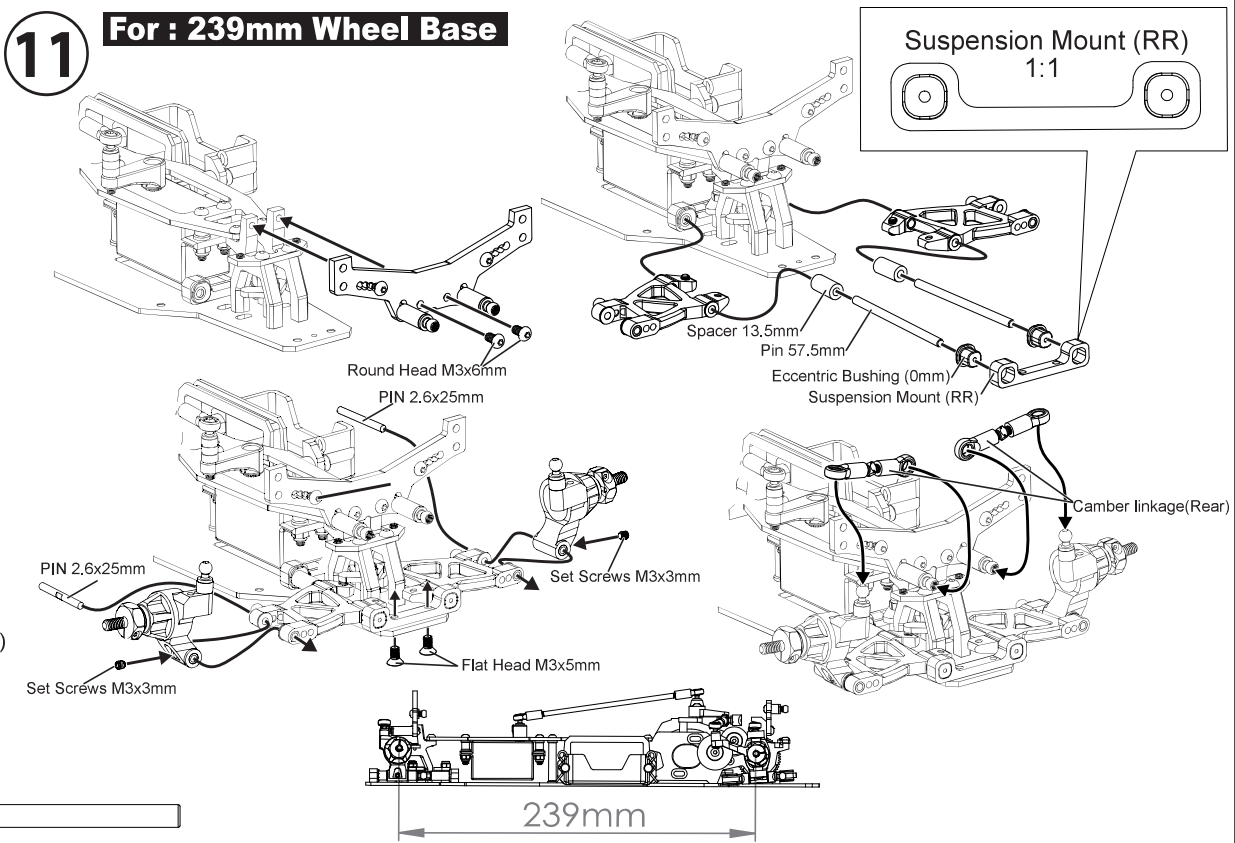

Round Head M3x6mm(4)

Flat Head M3x5mm(6)

Flat Head M3x10mm(2)

Set Screws M3x3mm(3)

Spacer 1.0mm(2)

Spacer 13.5mm(2)

Eccentric Bushing (0mm)(2)

Lock Nut M4(4)

PIN 3x57.5mm(2)

PIN 2.6x25mm(2)

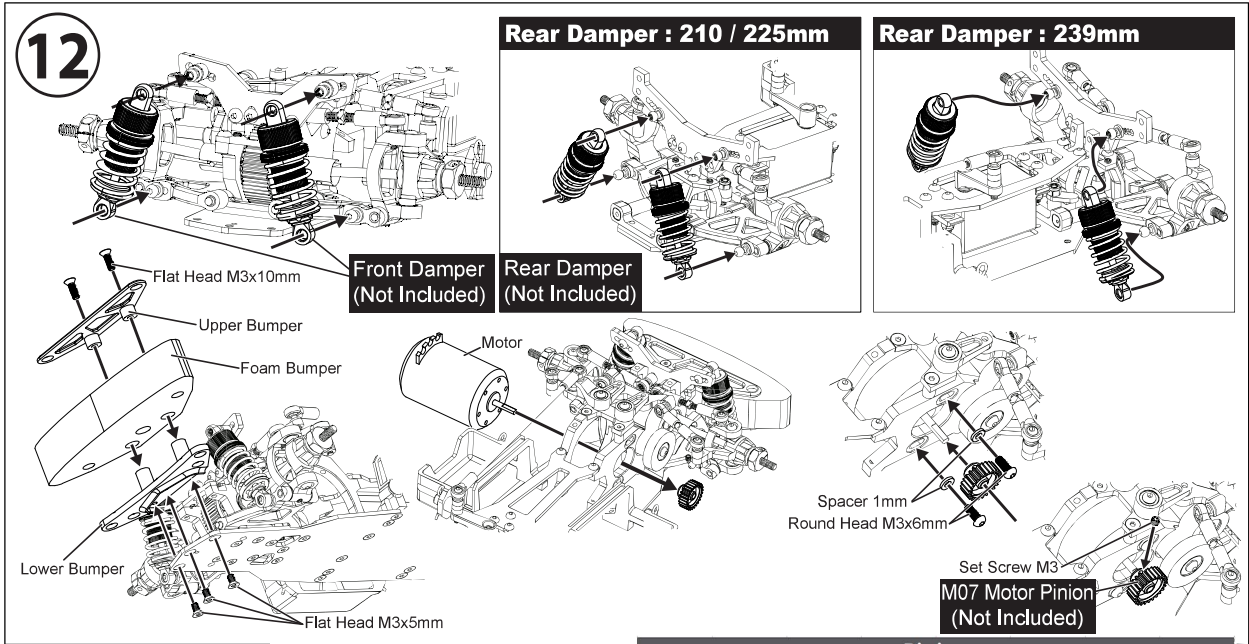

Internal Ratio	Diff. (T)	Spur (T)	Pinion							
			17T	18T	19T	20T	21T	22T	23T	24T
3.122	52T	37T	6.795	6.417	6.080	5.776	5.501	5.251	5.022	4.813
3.000	50T	37T	6.529	6.167	5.842	5.550	5.286	5.045	4.826	4.625

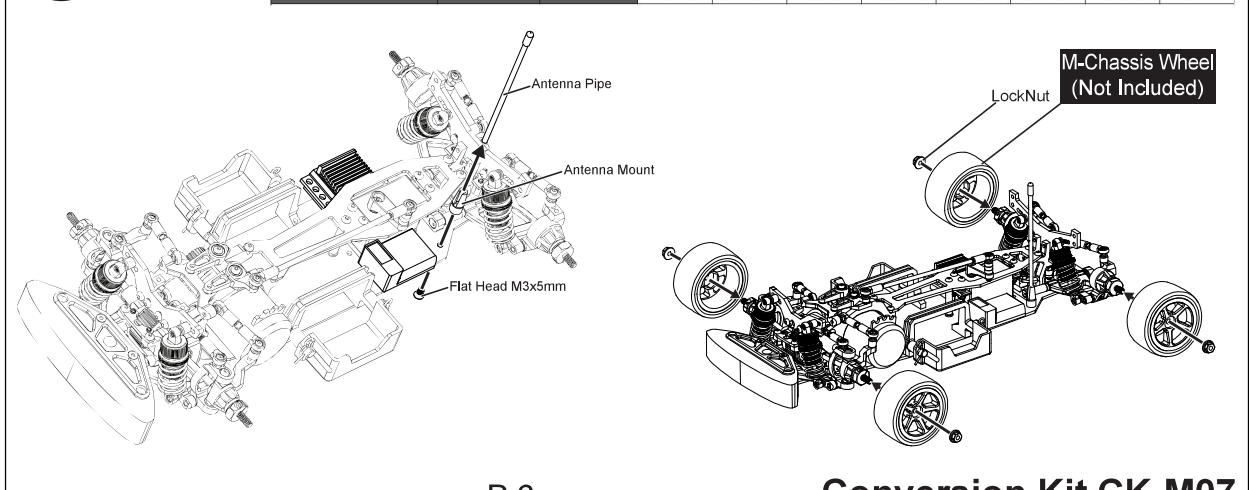

ROLL BAR BAG

Set Screw M3x3mm (4)

Round Head M3x6mm (6)

Round Head M3x10mm (2)

Flat Head M3x6mm (2)

Ball Ø4.8x5mm(2)

Ball Ø4.8x18mm(2)

Spacer 4mm (2)

Spacer 15mm (2)

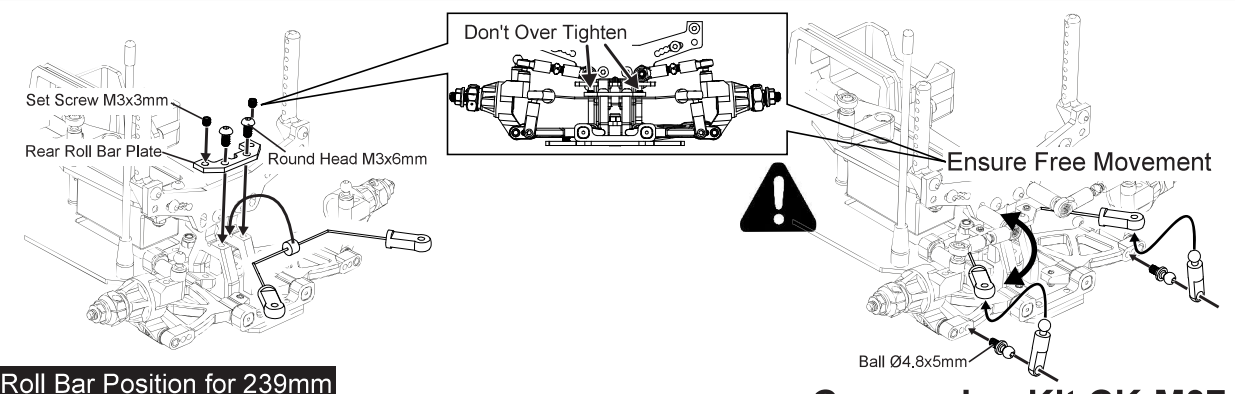
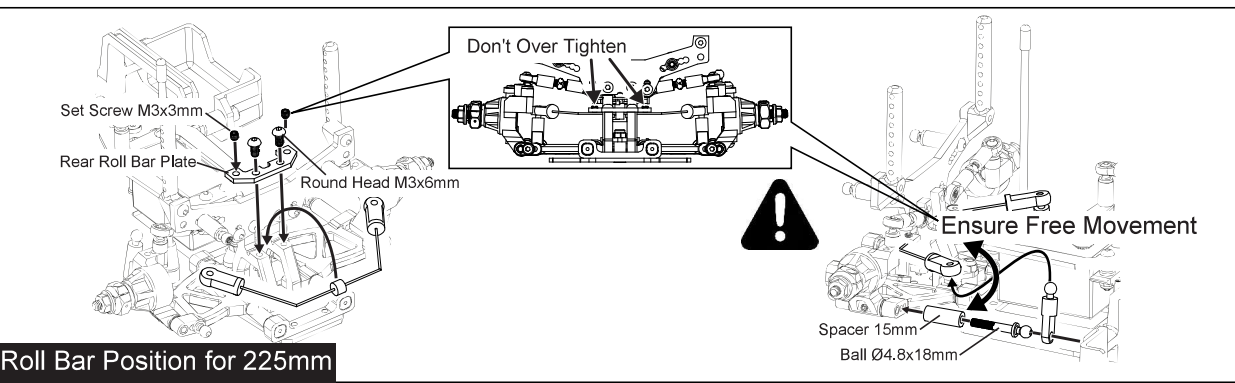
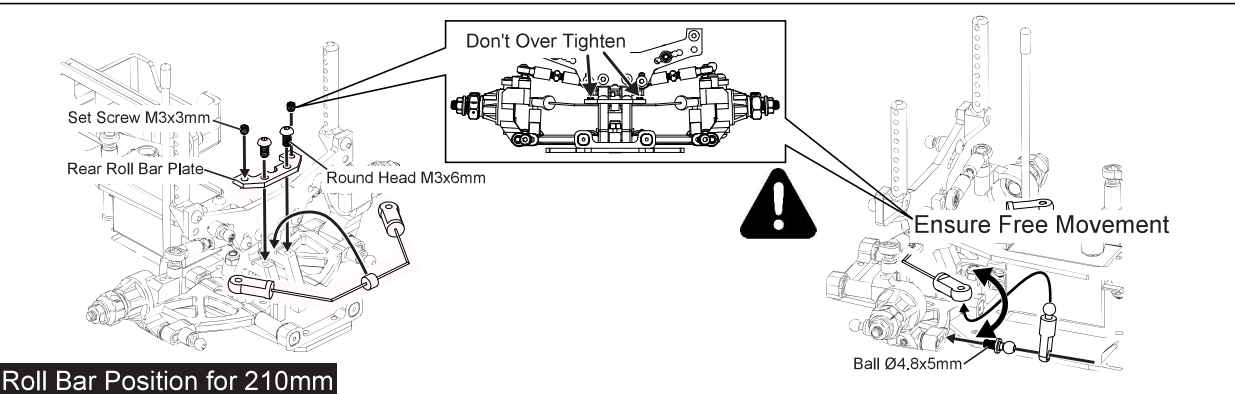
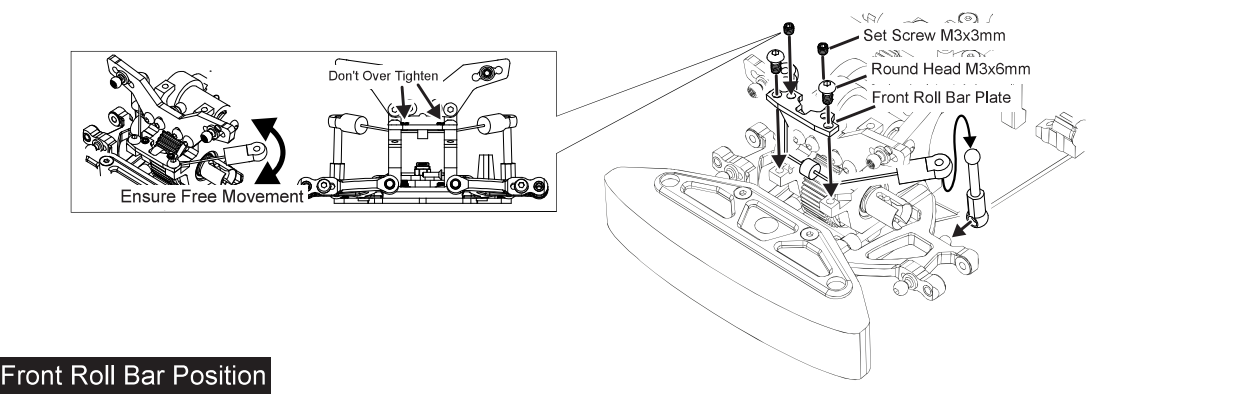
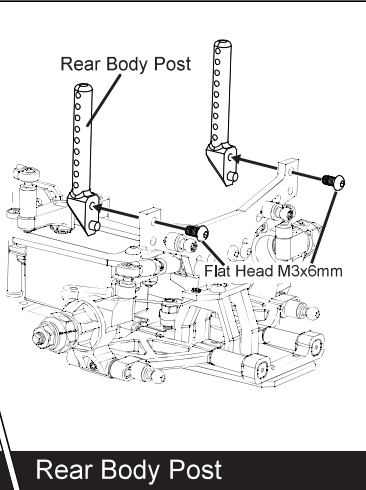
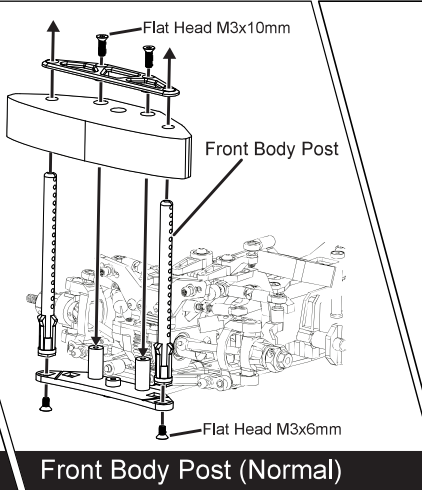
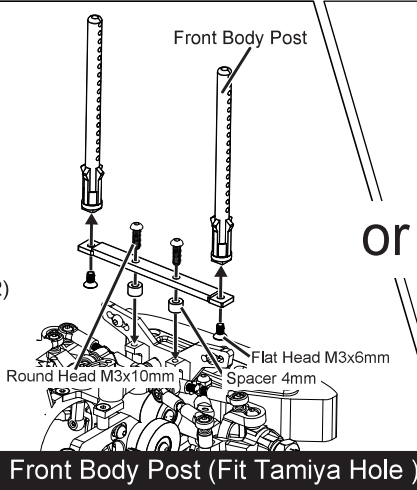

Name: **WW** Date: **2019/06** Time: **Night** Air Temp.: **27°C** Humidity: **70%~80%**

Track Condition: **Good** Track: **YMT Hong Kong (Indoor)** Track Temp. :

Body: **RCON CLUB 1275EST** Rear Spoiler: ESC: **Yeah Racing ESC** Motor: **Yeah Racing 13.5T**

Front

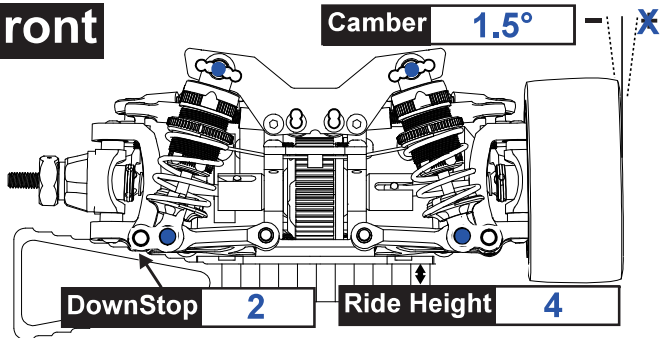

- Caster **4** deg.
- Diff. Fixed / Gear / Ball
- Diff. Oil **1000K** cst
- Drive Shaft **Double Joint**
- Front Arm # **54811 Carbon**
- C-Hub # **54810 Carbon**
- Upright # **54810 Carbon**



Damper Model	DBB-2050
Piston Hole	3 pcs
Hole Size Ø	1.2 mm
Shock Oil	300 cst
Spring	DBB Yellow
Rebound	0 mm
Stabilizer Ø	1.2 mm
Length	50 mm

Rear

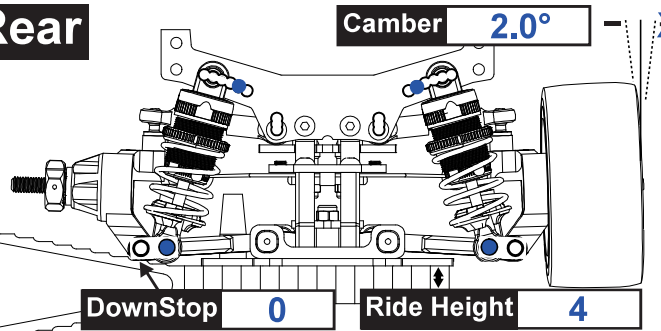

- RF Bushings **1** mm
- RR Bushings **0** mm
- Rear Arm # **54811 Carbon**
- Rear Hub # **54810 Carbon**



Damper Model	DBB-2050
Piston Hole	4 pcs
Hole Size Ø	1.2 mm
Shock Oil	300 cst
Spring	DBB Red
Rebound	0 mm
Stabilizer Ø	1.2 mm
Length	50 mm

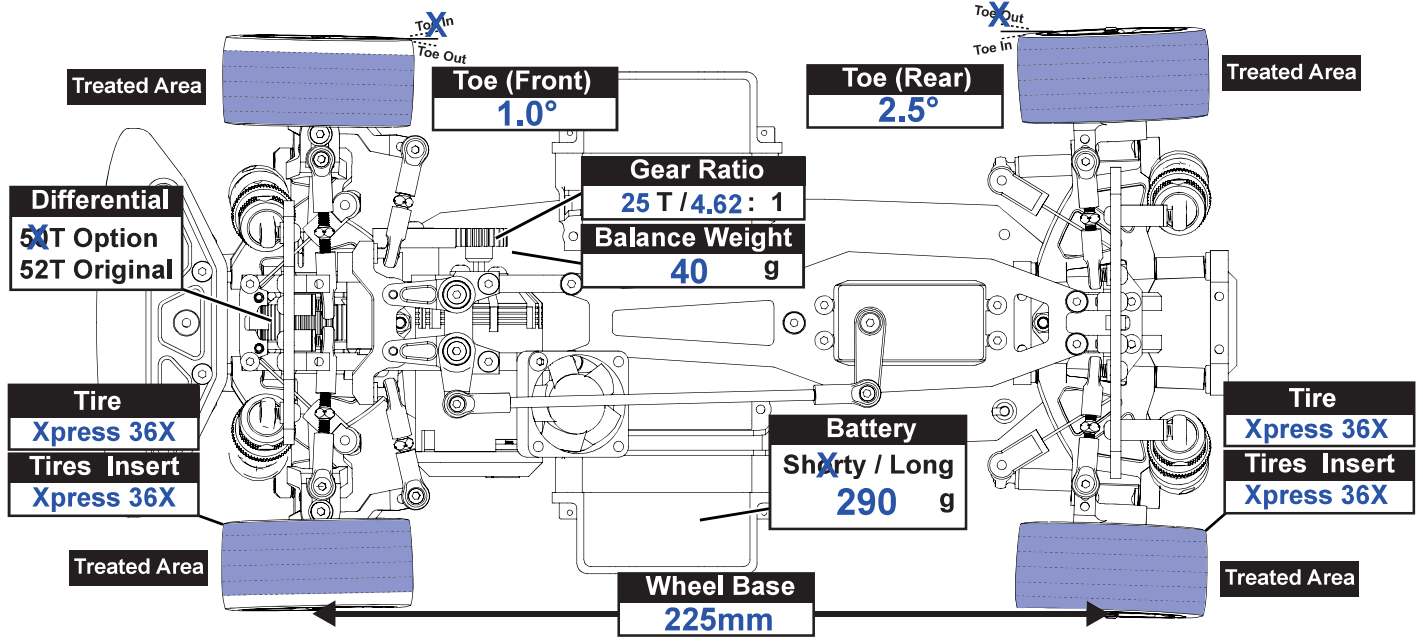
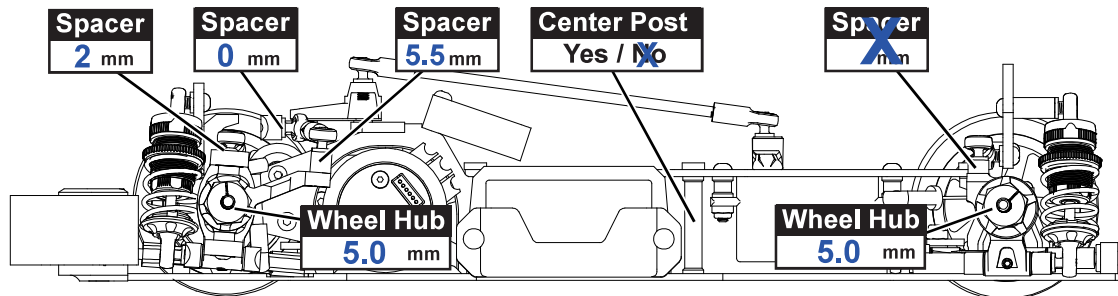

Remark

Name: _____ Date: _____ Time: _____ Air Temp. : _____ Humidity: _____

Track Condition: _____ Track: _____ Track Temp. : _____

Body: _____ Rear Spoiler: _____ ESC: _____ Motor: _____

Front

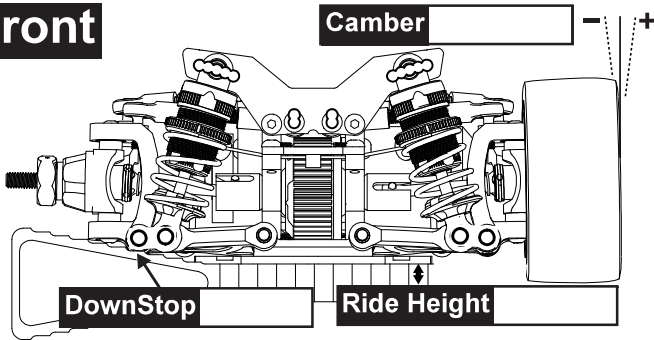

- Caster deg.
- Diff. Fixed / Gear / Ball
- Diff. Oil cst
- Drive Shaft
- Front Arm
- C-Hub
- Upright



- Damper Model
- Piston Hole pcs
- Hole Size Ø mm
- Shock Oil cst
- Spring
- Rebound mm
- Stabilizer Ø mm
- Length mm

Rear

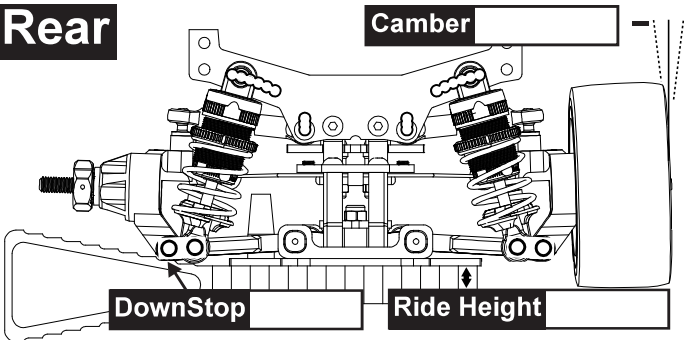

- RF
- RR
- RF Bushings mm
- RR Bushings mm
- Rear Arm
- Rear Hub



- Damper Model
- Piston Hole pcs
- Hole Size Ø mm
- Shock Oil cst
- Spring
- Rebound mm
- Stabilizer Ø mm
- Length mm

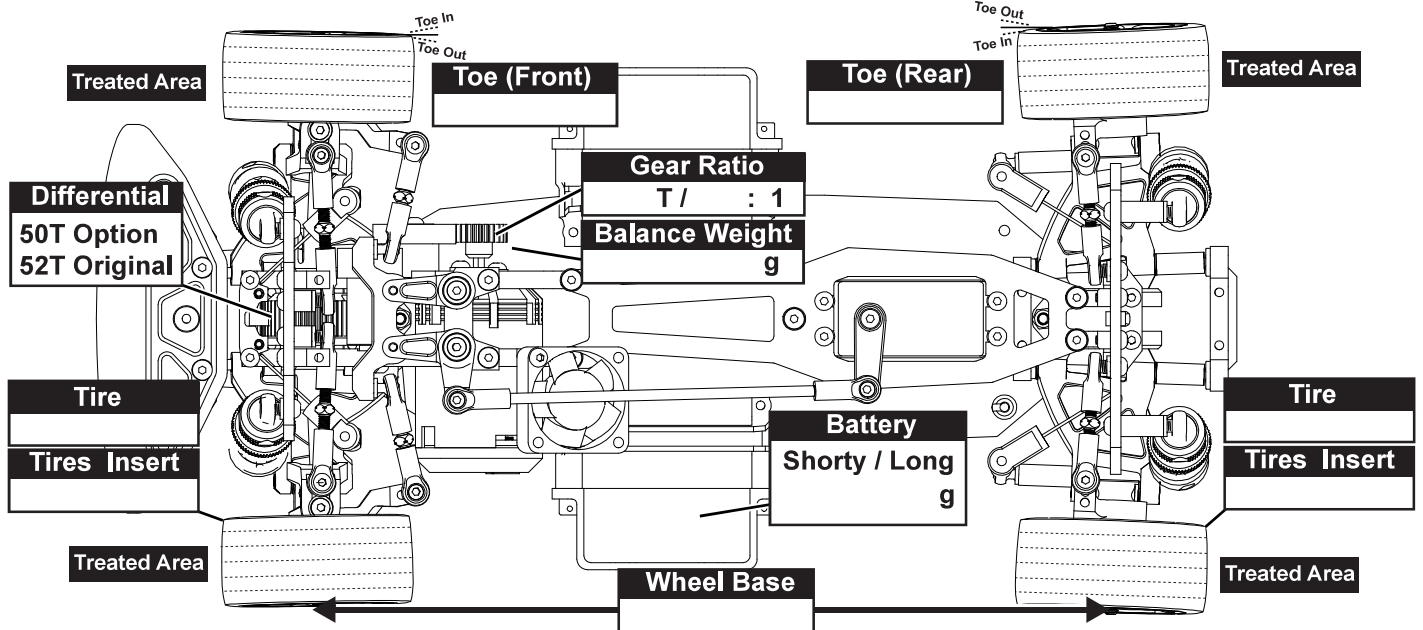
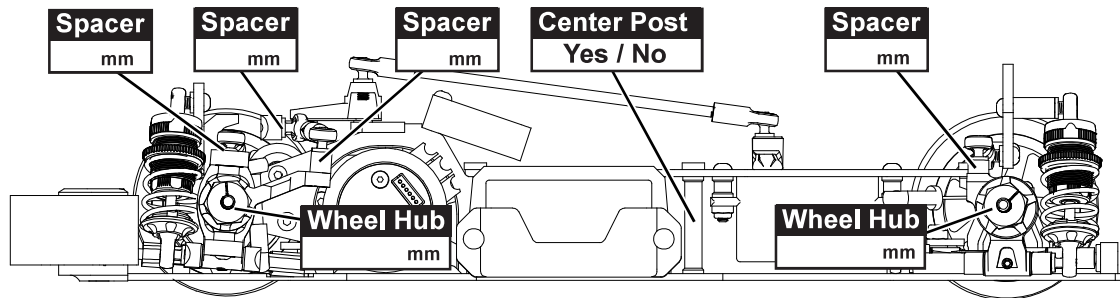

Remark
